

Chapter 7

Exploded View/ Parts List

- 7-1. Entire Unit
- 7-2. EBA-2X Acceptor Unit
- 7-3. EBA-PBX Unit

7-1. Entire Unit

7-1-1. Entire Unit Exploded View

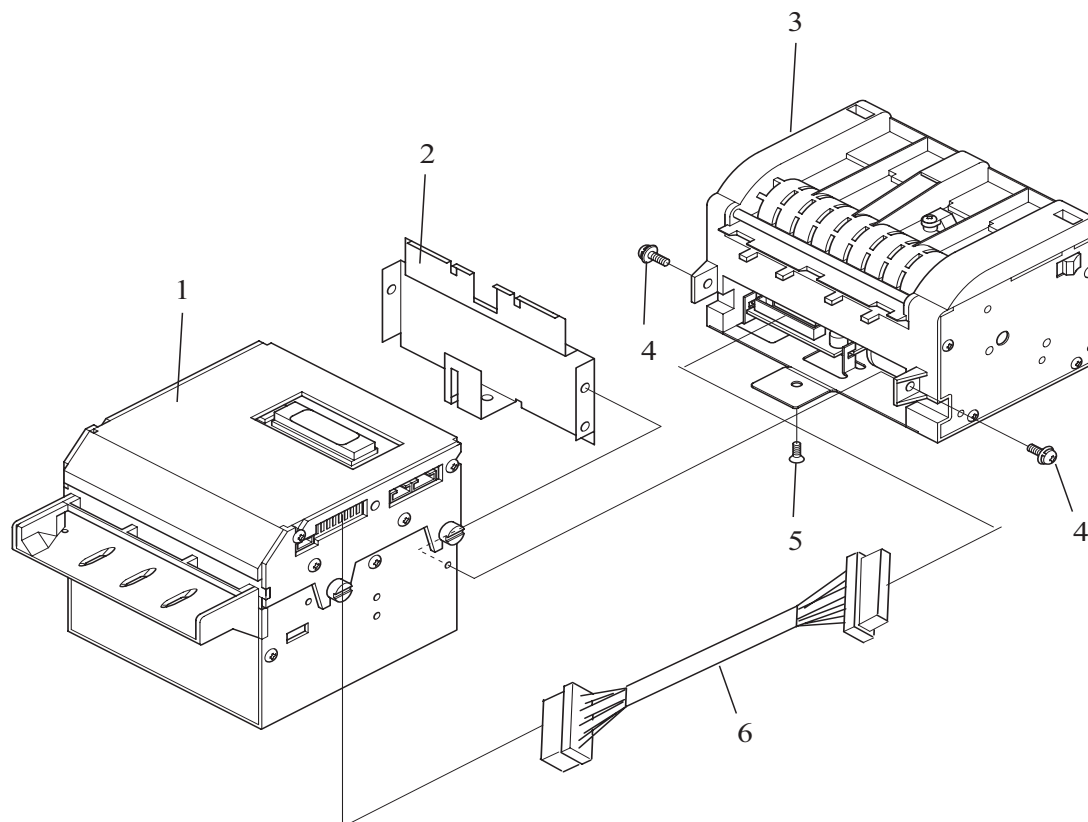

7-1-2. Entire Unit Parts List

No.	EDP#	Part Name	Description	Qty.	Remarks
1	Pending		EBA-20 Acceptor Head R	1	For EBA-20only
	117052		EBA-21 Acceptor Head R	1	For EBA-21only
	124969		EBA-22 Acceptor Head R	1	For EBA-22only
2	049324	0944PT0103E	Rear Cover R	1	For EBA-20,21
	065790	0655PT0103C	Wide Rear Cov R	1	For EBA-22only
3	117069		EBA-PB Unit Type1 HK R	1	For EBA-21:Type1
	092966		EBA-PB Unit Type 2 HK R	1	For EBA-21:Type2
	Pending		EBA-PB Unit Type 3 HK R	1	For EBA-21:Type3
	Pending		EBA PB2 Unit Type 1 HK R	1	For EBA-22:Type1
	092966		EBA PB2 Unit Type 2 HK R	1	For EBA-22:Type2
	Pending		EBA PB2 Unit Type 3 HK R	1	For EBA-22:Type3
4	033460		2.6x8 Pan Head W Sems Screw	2	
5	047740		2.6x6 Plate Bis	1	
6	049486	850-05-02A	Stacker Harness *R	1	

7-2. EBA-2X Acceptor Unit

7-2-1. EBA-2X Acceptor Unit Exploded View

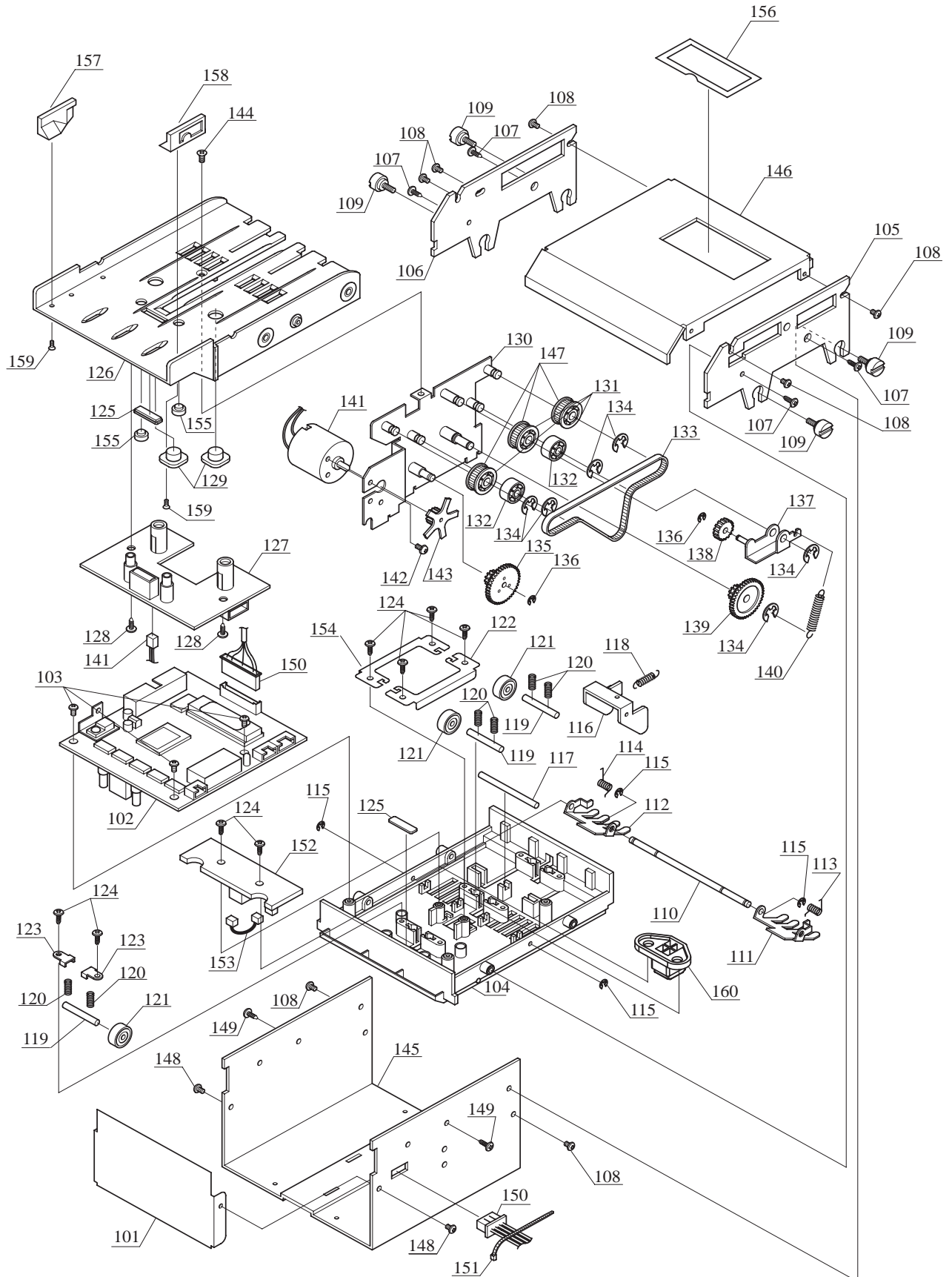

7-2-2. EBA-2X Acceptor Unit Parts List

No.	EDP#	Part Name	Description	Qty.	Remarks
101	049323	0944PT0102E	Front Cover *R	1	For EBA-20,21
	065789	0655PT0102C	Wide FR Cov *R	1	For EBA-22only
102	115934	601-995-06-01-01	CPU Board *R	1	For EBA-20,21
	119353	655-995-06-01-01	CPU Board *R	1	For EBA-22only
103	055413		2.6x6 Bind P Tight	3	
104	055410	0601RE0102C	Guide U Type-M *R	1	For EBA-20,21
	065793	0655RE0102B	Guide U Type-W *R	1	For EBA-22only
105	049356	0944AS0101D	Side Plate R Assy *R	1	
106	049357	0944AS0102D	Side Plate L Assy	1	
107	055413		2.6x6 Binde P Tight	4	
108	046073		2.6x4 Binde 3CM	7	
109	042379	SC4-7AK01A	Screw	4	
110	049331	0944SH0101	Shutter Shuft	1	For EBA-20,21
	065794	0655SH0101	Shutter Shuft	1	For EBA-22only
111	049326	0944PT0108C	Shutter R	1	
112	049327	0944PT0109C	Shutter L	1	
113	049359	0944KS0101B	Shutter Spring R	1	
114	049360	0944KS0102B	Shutter Spring L	1	
115	003705		E-Ring ϕ 2	4	
116	049330	0944PT0112	End Lever	1	
117	049332	0944SH0102	Lever Pin	1	
118	042383	TS-7AK02	Spring 3	1	
119	042376	SH2-7AK01	Pin 1	3	
120	005229	C-126	Spring	6	
121	042352	0944RE1008	Roller2 *R	3	
122	128782	0601PT0101	Spring BKT 3-R	1	
123	042361	0944PT1003	Spring BKT 1 *R	2	
124	055413		2.6x6 Binde P Tight	8	
125	040343	0943RE1008	Reflection Sensor LENS *R	2	
126	055411	0601RE0101F	Guide D Type-M R	1	For EBA-20,21
	065792	0655RE0101B	Guide D Type-W R	1	For EBA-22only
127	118541	601-990-06-02B-01	Sensor Board	1	
128	055413		2.6x6 Bind P Tight	2	
129	042353	0944RE1009	Sensor Cover *R	2	
130	064595	0944AS1001	Motor BKT Assy *R	1	
131	064601	0944RE1005	Pulley1 *R	3	
132	064600	0944RE1004	Roller 1 *R	2	
133	042385		103MXL4.8V Timing Belt	1	
134	003707		E-Ring ϕ 3	6	
135	064598	0944RE1002	Gear 1 *R	1	
136	003705		E-Ring ϕ 2	2	
137	042392	0944AS1002	Pulley Arm ASSY R	1	

No.	EDP#	Part Name	Description	Qty.	Remarks
138	064603	0944RE1007	Pulley 2 *R	1	
139	064599	0944RE1003	Gear 2 *R	1	
140	005230	E-534	Spring	1	
141	042384	OK-1217J	DC Motor R	1	
142	003600		M3x5 SCREW WITH WASHER	1	
143	064597	0944RE1001	Encoder Gear *R	1	
144	014548		2.6x5 Plate BC	1	
145	049322	0944PT0101E	Frame R	1	For EBA-20,21
	065788	0655PT0101C	Wide Frame R	1	For EBA-22only
146	049325	0944PT0107F	Cover *R	1	For EBA-20,21
	065791	0655PT0104D	Wide Cover R	1	For EBA-22only
147	064602	0944RE1006	Frangé *R	3	
148	046073		2.6x4 Binde 3CM	2	
149	055413		2.6x6 Binde P Tight	2	
150	055534	990-05-01B	Relay Harness R	1	
151	031977	T-18S	Convex *P	1	
152	118540	601-990-06-03B-01	MAG Sensor Board R	1	For EBA-21,22
153	055535	990-05-02A	MAG Harness R	1	For EBA-21,22
154	128781	0601PT0102	Spring BKT 3-L	1	
155	040342	0943RE1009	Sensor Bush ϕ 5 *R	2	
156	056813	0606RE0501A	ROM Cover *R	1	
157	059049	0944RE0105A	EBA Guide (L) R (Type 2)	1	EBA-20,21:68mm EBA-22only:75mm
	051884	0944RE0104A	EBA Guide (L) R (Type 3)		EBA-20,21:~72mm EBA-22only: 70/80mm
	061500	0944RE0107B	EBA Guide (L) R (Type 4)		EBA-20,21: 60/71/78mm EBA-22only: 68/78/85mm
	078296	0944RE0109C	EBA Guide (L) R (Type 5)		EBA-20,21: 67/78mm EBA-22only: 75/85mm
158	059050	0944RE0106A	EBA Guide (R) R (Type 2)	1	EBA-20,21:68mm EBA-22only:75mm
	051883	0944RE0103A	EBA Guide (R) R (Type 3)		EBA-20,21:~72mm EBA-22only: 70/80mm
	061501	0944RE0108B	EBA Guide (R) R (Type 4)		EBA-20,21: 60/71/78mm EBA-22only: 68/78/85mm
	078297	0944RE0110C	EBA Guide (R) R (Type 5)		EBA-20,21: 67/78mm EBA-22only: 75/85mm
159	058834		M2 x 6 Plate Bis Tapping P Tight	2	
160	066661	0601RE0103	MG Dummy	1	For EBA-20only

7-3. EBA-PBX Unit

7-3-1. EBA-PBX Unit Exploded View

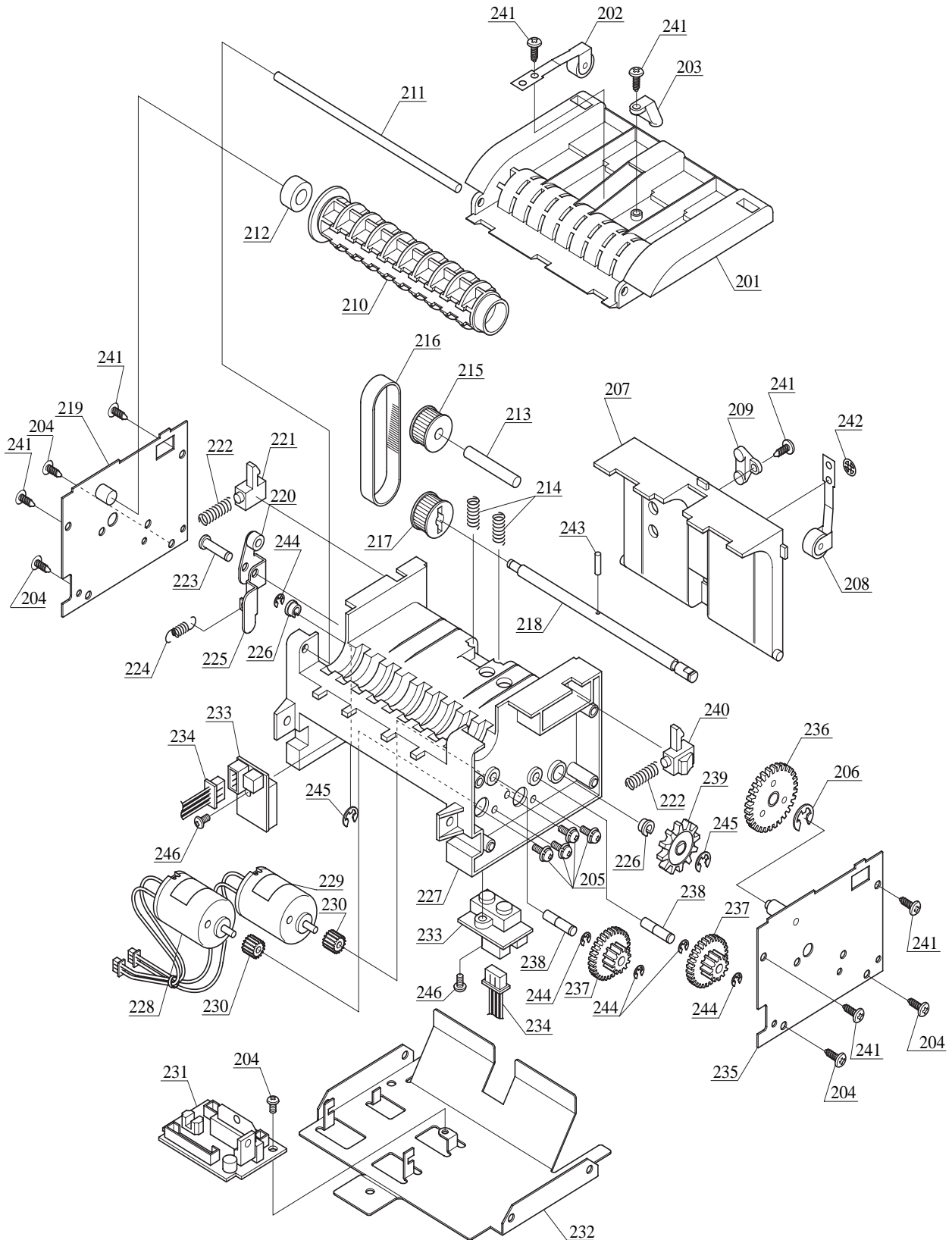

7-3-1. EBA-PBX Unit Parts List

No.	EDP#	Part Name	Description	Qty.	Remarks
201	065798	0655RE0202A	Wide Guide U R	1	For EBA-PB2only
	061077	0632RE0102A	Guide U R	1	For EBA-PBonly
202	061086	0632AS0101A	Roller Arm B Assy R	1	
203	057377	990-03-21	Prism *P	1	
204	014547		2.6x5 Bind	5	
205	003609		3x6 Pan Head W Sems	4	
206	003709		E-Ring φ5	1	
207				1	For EBA-PB2:Type1only
	065802	0655RE0203A	Wide Rear Guide	1	For EBA-PB2:Type2only
	061069	0632RE0103B	Rear Guide B R	1	For EBA-PB:Type1only
	061249	0632RE0110B	Rear Guide A R	1	For EBA-PB:Type2only
208	061086	0632AS0101A	Roller Arm B Assy R	1	For EBA-PB2:Type1only
	061250	0632AS0104	Roller Arm A Assy	1	For EBA-PB2:Type2only
	061086	0632AS0101A	Roller Arm B Assy R	1	For EBA-PB:Type1only
	061250	0632AS0104	Roller Arm A Assy	1	For EBA-PB:Type2only
209	057377	990-03-21	Prism *P	1	For EBA-PB2:Type1,2 For EBA-PB:Type1,2
210	065799	0655RE0204A	PB Guide W R	1	For EBA-PB2
	057243	0606RE0102B	PB Stopper R	1	For EBA-PB
211	065800	0655SH0201	Cover Shaft W	1	For EBA-PB2
	061085	0632SH0101	Cover Shaft	1	For EBA-PB
212	014156	OWC-6-12-6-IN	One-way Clatch	1	
213	061080	0632SH0104	Pulley Pin	1	
214	061095	C-170	Spring	2	
215	061075	0632RE0106A	Driven Roller *R	1	
216	061072		52MXL6.4V Timing Belt	1	
217	061076	0632RE0105B	Drive Roller R	1	
218	065801	0655SH0202	Drive Shaft W	1	For EBA-PB2only
	061082	0632SH0102	Drive Shaft	1	For EBA-PBonly
219	061083	0632AS0103B	SIDE COV L AS R	1	
220	052580	0943RE0515C	Arm Roller 1 R	1	
221	061073	0632RE0108A	Guide Latch L R	1	
222	061094	C-141	Spring (NO.1042)	2	
223	061078	0632SH0106	PB Arm Shaft	1	
224	035276	E-573	Spring	1	
225	057202	0606AS0105B	Stopper Arm Assy *R	1	
226	026109	0632RE1001	(RE-7V11) Shaft Receiver *R	2	
227	065797	0655RE0201A	Wide PB Frame R	1	For EBA-PB2only
	061081	0632RE0101B	PB Frame *R	1	For EBA-PBonly
228	068572	632-992-05-02A-01	(HK) PB Motor R	1	
229	068571	632-992-05-03A-01	(HK) Feed Motor R	1	
230	057246	0606RE0105B	GEAR M0.5-10 R	2	
231	118542	632-992-06-21-01	(HK) PB Board R	1	
232	065796	0655PT0201D	Wide Under Frame R	1	For EBA-PB2only
	061068	0632PT0102A	Under Frame R	1	For EBA-PBonly

EBA-2X-PBX Parts List

No.	EDP#	Part Name	Description	Qty.	Remarks
233	061098	992-03-22A	Right Guide Board R	2	
234	061096	992-05-01A	Right Guide Harness	1	
235	061084	0632AS0102B	Side Cov R AS R	1	
236	057245	0606RE0104A	PB Gear R	1	
237	052544	0943RE0224C	TR Gear 3 R	2	
238	061079	0632SH0105	Gear Shaft	2	
239	059526	0612RE0106B	CON Gear *R	1	
240	061074	0632RE0107A	Guide Latch R R	1	
241	061070		2.6x5 Bind P Tight	6	
242	026073	CSTW-3	CS Stopping Ring	1	For EBA-PB2:Type1,2 For EBA-PB:Type1,2
243	037882		2x10 Pallarel Pin	1	
244	003705		E-Ring ϕ 2	5	
245	003707		E-Ring ϕ 3	2	
246	061502		2.6x10 Bind P Tight FE	2	
247	061070		2.6x5 Bind P Tight	1	For EBA-PB2:Type1,2 For EBA-PB:Type1,2