

1,000 Note Cash Box

CASH HANDLING SOLUTION



**JCM Technology Delivers
the Highest Performance and
Security to Worldwide Markets**

1,000 Note Capacity

Compact, Lightweight Design

Vertical Note Stacking

Lockable, Removable Cash Box

Option for the WBA Platform

The **1,000 Note Cash Box** provides vertical note stacking for the WBA platform. Lockable, removable cash box for added security.



LEADING SOLUTIONS. LASTING RELATIONSHIPS.

1,000 Note Cash Box

SPECIFICATIONS

Power Requirements

95 VAC to 135 VAC w/Power Supply (50 to 60 Hertz) or 12V DC (Max 20 VA)

Hopper/Magazine Capacity

1,000 Notes

Shipping Weight

Weight with Empty Hopper - 2.3 kg / 5 lb

Technical Support

Training classes are available for all JCM products.

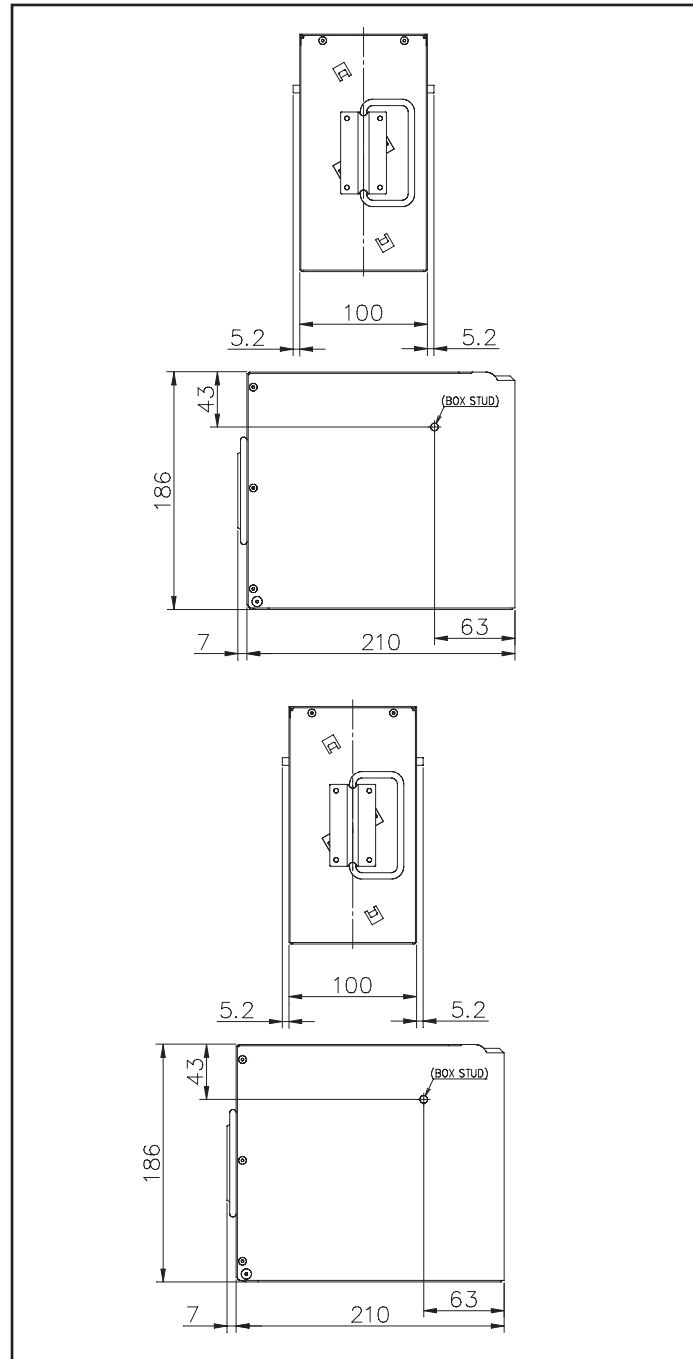

JCM and the JCM logo are registered trademarks of Japan Cash Machine Co., Lt. and JCM American Corporation. All other marks are registered trademarks of their respective owners.

REV #: 03312004

JCM American Corporation
925 Pilot Road • Las Vegas, Nevada 89119
Tel: 702-651-0000 Fax: 702-644-5512 800.683.7248
e-mail: sales@jim-american.com
www.jim-american.com

JCM Germany GmbH
Muendelheimer Weg 60 • D-40472 Duesseldorf
Tel: +49-211-5306450 Fax: +49-211-53064565
e-mail: info@jim-germany.com
www.jim-germany.com

